

REVISIONS				
SYM	DESCRIPTION	DATE	APPROVED	SYM
△	MODIFY RJ PLUG	30/DEC/10'	AARON	△
△	REVISED DRAWING	18/NOV/19'	ABER	△

****CUSTOMER DRAWING FOR REFERENCE ONLY, SAMPLES APPROVAL ARE REQUIRED!!**

195

P1
P2
8P8C SHIELDED R 50u"

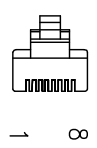
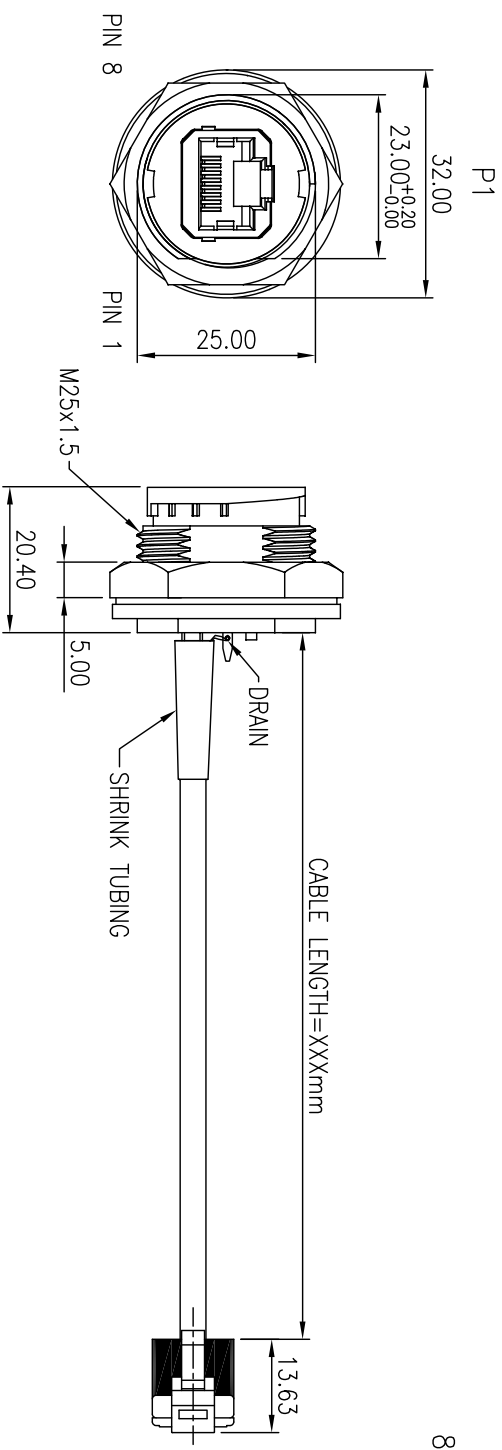

1. CABLE COMPONENT:
 SPECIFICATION:
 1. CABLE COMPONENT:
 A. SIZE OF CONDUCTORS: FTP CSE #26AWG 4PAIR OD:5.6mm LAN CABLE.
 B. PLENUM SHIELD: DRAIN WIRE(TINNED COPPER CONDUCTOR) AND ALUMINUM-MYLAR TAPE.
 C. COLOR: BLACK.
 2. PLUG:
 A. TYPE: SHORT MODULAR METAL SHIELDED TYPE 8P8C ,GOLD PLATING 50u".
 B. MATERIAL: PC UL 94V-2
 C. MATERIAL SHELL: BRASS.
 3. RJ45 JACK:
 HOUSING: HIGH TEMP, THERMOPLASTIC FLAMMABILITY RATING UL 94V-0.
 NUT: ENGINEERING THERMOPLASTIC FLAMMABILITY RATING UL 94V-0.
 CONTACTS: PHOSPHOR BRONZE, GOLD PLATING OVER NICKEL,
 TIN PLATING OVER NICKEL IN SOLDER AREA
 SHIELDED: BRASS WITH NICKEL PLATED
 GASKET: SILICONE
 NUT INSTALLATION TORQUE RANGE: 16~18KG-CM

WIRING: 568B

P1	COLOR	P2
1	White/Orange	1
2	Orange	2
3	White/Green	3
6	Green	6
4	Blue	4
5	White/Blue	5
7	White/Brown	7
8	BROWN	8

Drain Wire to Drain Wire

4. SHRINK TUBING: $\phi 0.15 \times 10\text{mm}$ & $10 \times 30\text{mm}$.
 5. EPOXY SETS UP THE ESTER.
 6. IP67, PANEL THICKNESS: 1.6mm~2.5mm.

TOLERANCES UNLESS OTHERWISE SPECIFIED		SIGNATURES		DATE		MODEL	
±0.25		DRAWN	AARON	22/DEC/10'	TITLE		
CHECKED	PEGGY	22/DEC/10'			CABLE ASSEMBLY		
APPROVALS							
NO.	CA004-100802-						

MMT CORPORATION