

8 7 6 5 4 3 2 1  
 VI.2 NOTE: THIS DEVICE IS ROHS COMPLIANT.

|     |                | REVISIONS  |          |     |             |      |          |
|-----|----------------|------------|----------|-----|-------------|------|----------|
| SYM | DESCRIPTION    | DATE       | APPROVED | SYM | DESCRIPTION | DATE | APPROVED |
| Δ   | REVISE DRAWING | 18/NOV/19' | ABER     | Δ   |             |      |          |
| Δ   |                |            |          | Δ   |             |      |          |

**\*\*CUSTOMER DRAWING FOR REFERENCE ONLY, SAMPLES APPROVAL ARE REQUIRED!!**

084

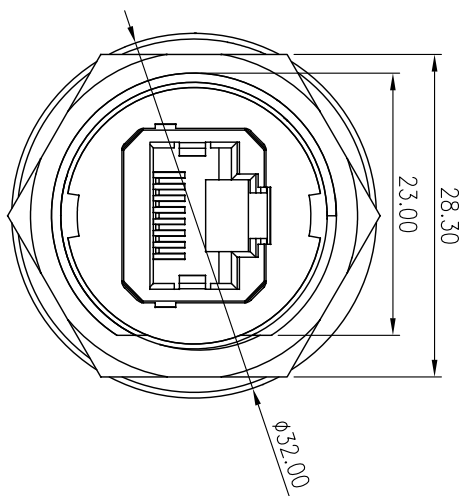
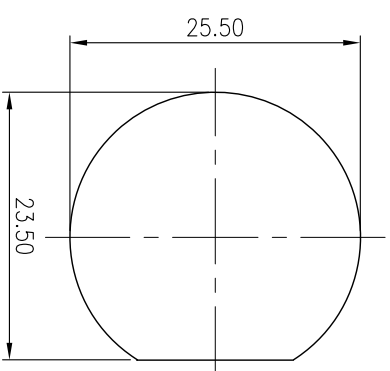
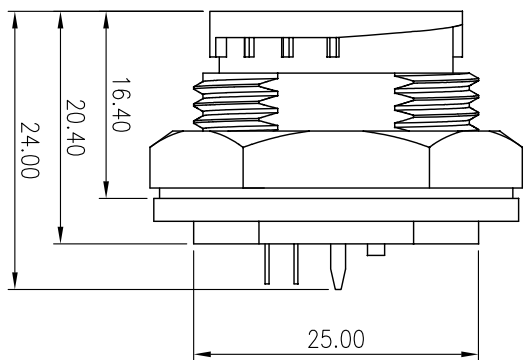
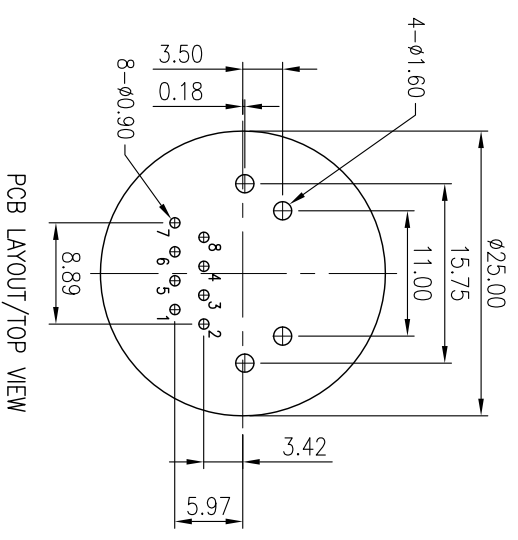
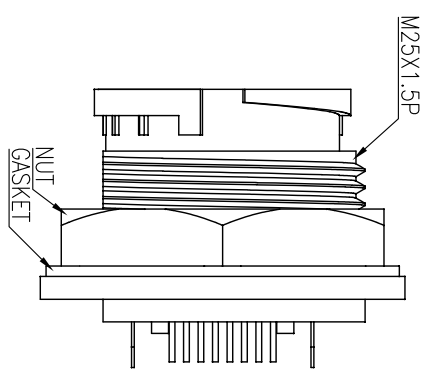

**MATERIALS:**  
 HOUSING: HIGH TEMP, THERMOPLASTIC FLAMMABILITY RATING UL 94V-0.  
 NUT: ENGINEERING THERMOPLASTIC FLAMMABILITY RATING UL 94V-0.  
 CONTACTS: PHOSPHOR BRONZE, GOLD PLATING OVER NICKEL,  
 TIN PLATING OVER NICKEL IN SOLDER AREA  
 SHIELDED: BRASS WITH NICKEL PLATED  
 GASKET: SILICONE  
 NUT INSTALLATION TORQUE RANGE: 16~18KG-CM

| TOLERANCES UNLESS OTHERWISE SPECIFIED |           | SIGNATURES |       | DATE       |       | MODEL                     |  |
|---------------------------------------|-----------|------------|-------|------------|-------|---------------------------|--|
| ±0.25                                 |           | DRAWN      | AARON | 21/AUG/09' | TITLE | RJ45 WATERPROOF CONNECTOR |  |
| Δ                                     | UNIT mm   | CHECKED    | PEGGY | 21/AUG/09' | NO.   | RWP-22                    |  |
|                                       | SCALE 2/1 | APPROVALS  |       |            |       |                           |  |

MMT CORPORATION